



## ***Front Projection Screen Installation Methods***





**CinemaSource ,  
18 Denbow Rd., Durham, NH 03824  
[www.cinemasource.com](http://www.cinemasource.com)**

*CinemaSource Technical Bulletins. Copyright 2002 by CinemaSource, Inc.  
All rights reserved. Printed in the United States of America.*

No part of this bulletin may be used or reproduced in any manner whatsoever without written permission, except in brief quotations embodied in critical reviews.

*CinemaSource* is a registered federal trademark.

For information contact: The CinemaSource Press, 18 Denbow Rd. Durham, NH 03824



## ***Front Projection Screen Installation Methods***

### **Front Screen Installation Methods**

- Projector/screen alignment ----- Page 4
- Mounting flat screens ----- Page 6
- Mounting motorized screens ----- Page 7
- Snaking screen power wires ----- Page 10
- Understanding AC power ----- Page 13

### **Glossary**

- A collection of projection screen-related terminology ----- Page 14

## **SCREEN MANUFACTURERS PROFILED IN THIS GUIDE:**

DA-LITE SCREEN, 3100 North Detroit St., Warsaw, IN 46581 800-622-3737,  
[www.da-lite.com](http://www.da-lite.com)

DRAPER, 411 S. Pearl St., Spiceland, IN 47385 800-238-7999,  
[www.draperinc.com](http://www.draperinc.com)

VUTEC Corporation, 5900 Stirling Road, Hollywood, FL 33021 800-770-4700,  
[www.vutec.com](http://www.vutec.com)

STEWART FILMSCREEN, 1161 West Sepulveda Blvd., Torrance, CA 90502  
800-762-4999, [www.stewartfilm.com](http://www.stewartfilm.com)

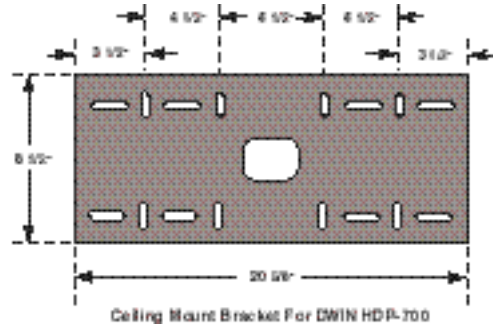
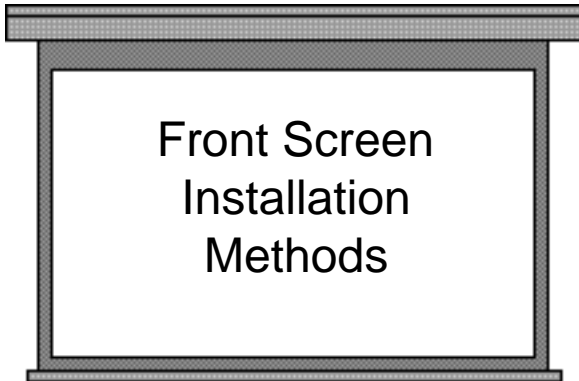

In this section we will discuss some of the basic principles involved when mounting front projection screens.

Below we illustrate one of the most important principles involved; the physical alignment of the projector and screen. Simply, the screen and projector need to be aligned to each other properly. If they are not aligned so they are "square" to each other, or the dimensions significantly deviate from the manufacturers recommendations, you may have a difficult time adjusting the projector. As a rule of thumb, always preplan the location of the screen and projector and double check your numbers before you start up the power tools. As our diagram below illustrates, you can verify proper alignment of the projector/screen system with a tape measure.

Checking the X and Y dimensions will tell you if your installation is square. The C dimension is equally important and comes from the projector manufacturer's installation manual. On the next page we illustrate the installation diagram for the Dwin HDP-700 front projector.

Note: If you are installing a ceiling mount projector and are wondering how exact the  $X1 = X2$  and  $Y1 = Y2$  relationships should be, don't fret. Plus or minus 1" to 2" is fine. This works because the manufacturers generally build in flexibility in the ceiling mount bracket so that the projector can be twisted a few degrees left and right. In the diagram above, we show the ceiling mount bracket supplied by Dwin. Note that the mounting holes are oblong. This allows one to rotate the projector slightly so the image projected is easily centered on the screen.

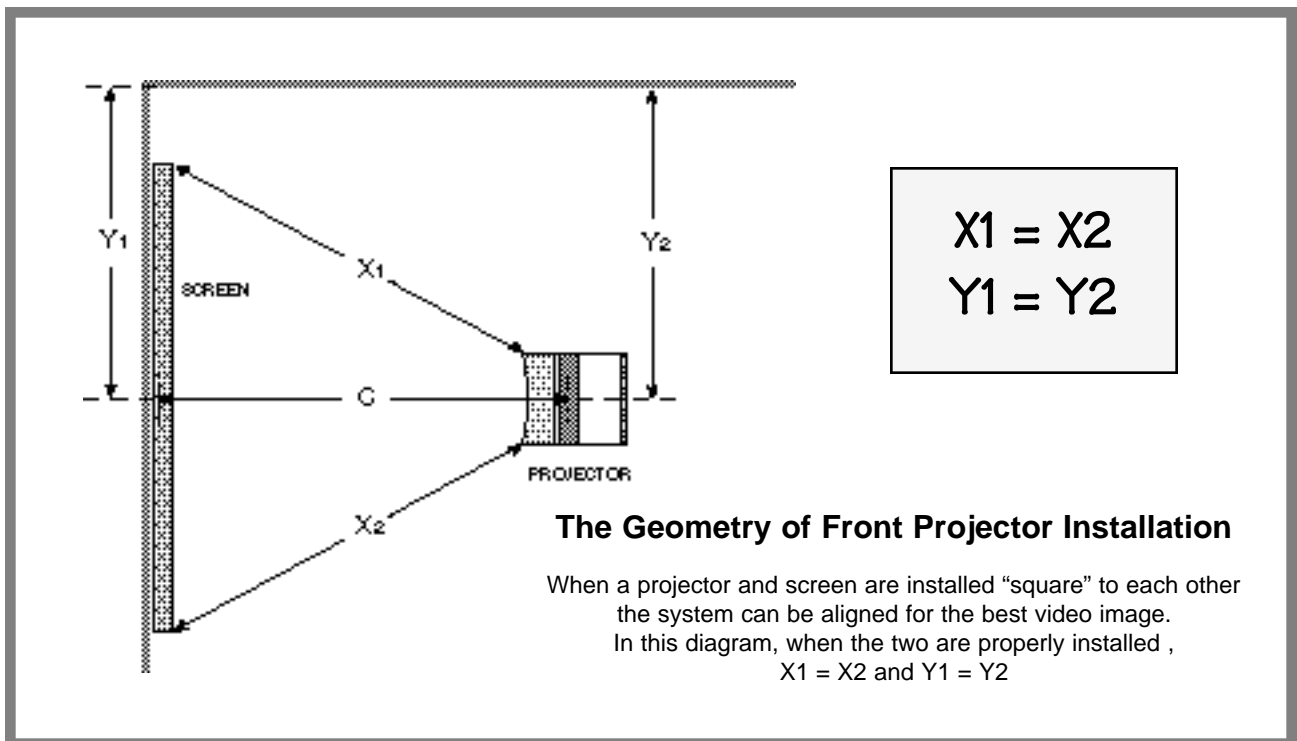

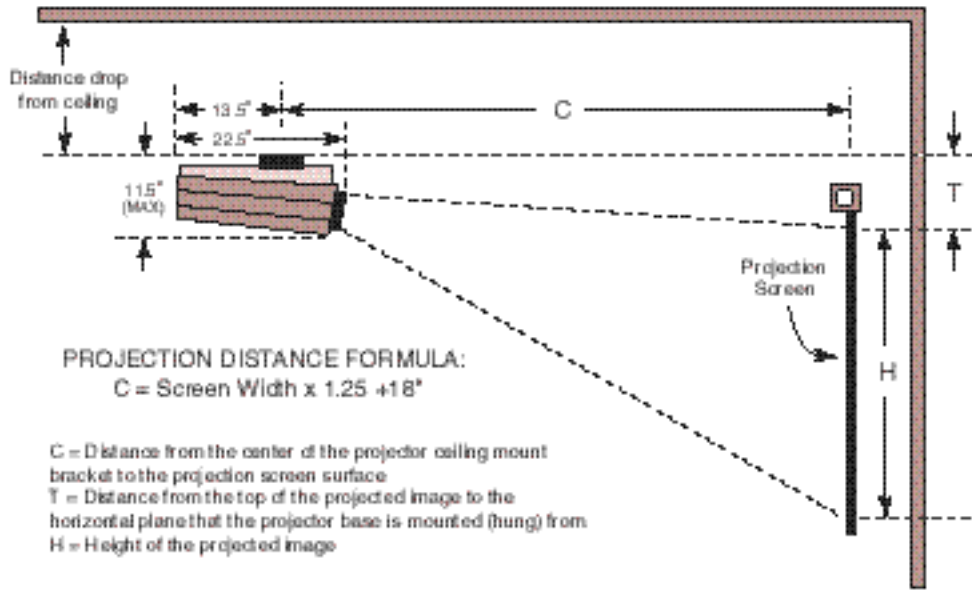

PROJECTION DISTANCE FORMULA:  
 $C = \text{Screen Width} \times 1.25 + 18"$

C = Distance from the center of the projector ceiling mount bracket to the projection screen surface  
 T = Distance from the top of the projected image to the horizontal plane that the projector base is mounted (hung) from  
 H = Height of the projected image

SCREEN SIZE (diagonal)	ASPECT RATIO	SCREEN HEIGHT	SCREEN WIDTH	C	T
84"	4:3	50"	67"	104"	
100"	4:3	60"	80"	118"	
120"	4:3	72"	96"	138"	
106"	16:9	52"	92"	133"	
119"	16:9	58"	104"	148"	

(From The DWIN HDP-700 Installation Manual, courtesy of DWIN Electronics)

## Front Projector Installation Chart As Supplied From The Manufacturer



Flat screens are generally constructed of black anodized, extruded aluminum frames, 1.5" wide, with a sheet of screen material attached by heavy-duty velcro or snaps to the back side of the frame. This is referred to as a "shadow box" design because you look "through" the frame to the screen surface.. For those that are concerned about reflections from projector overscan, the frame can be ordered with Black Velvet coating applied (additional 5% cost). As our diagrams illustrate, Flat screens can be mounted on the wall via the supplied wall mounting brackets or used freestanding with the optional screen leg kit.

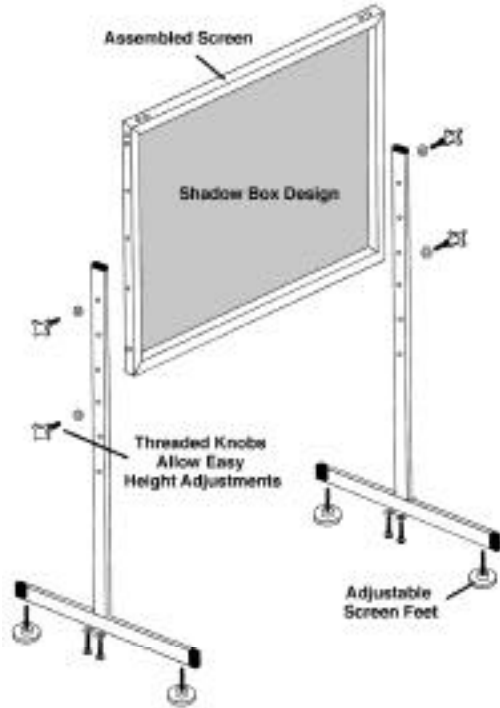

For Temporary Use, Flat Screens can be used on Leg Assemblies

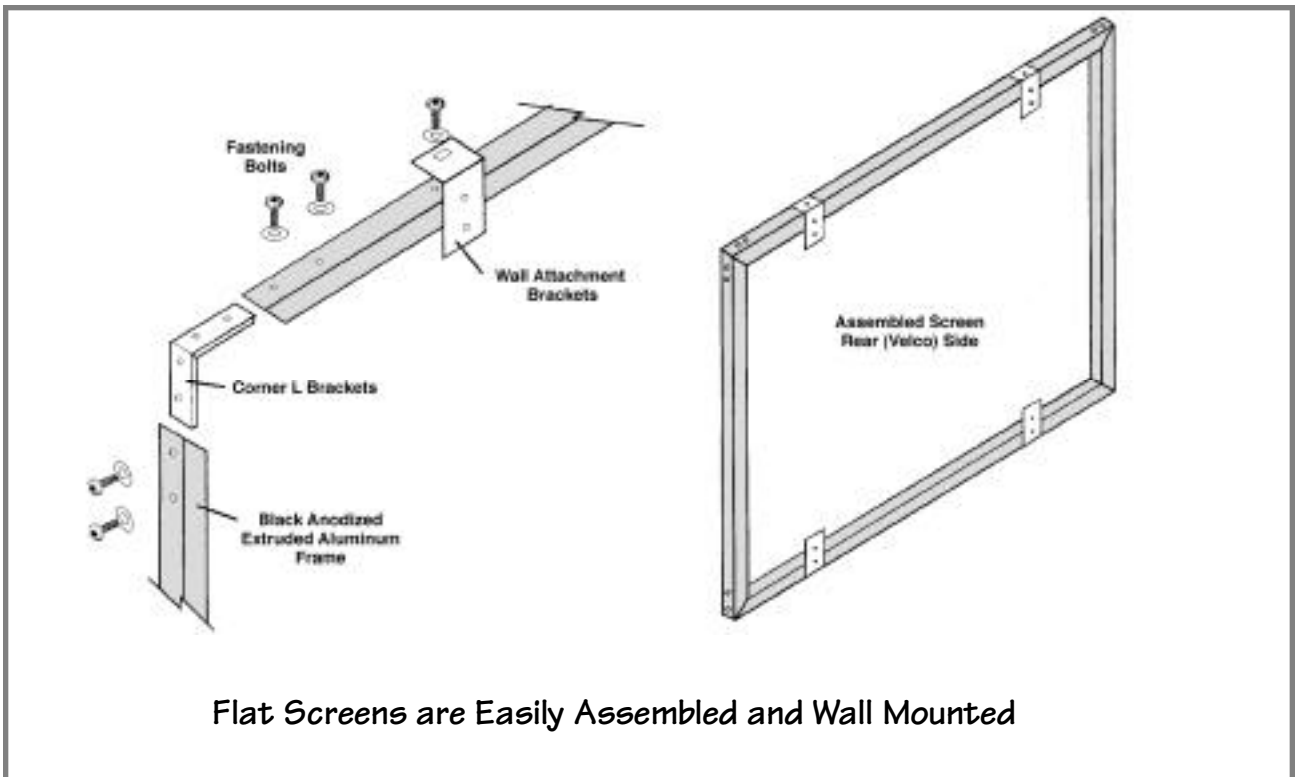

Flat Screens are Easily Assembled and Wall Mounted



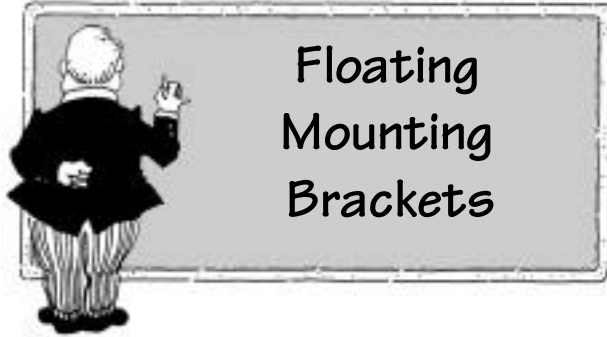

## Floating Mounting Brackets

A very common problem occurs when mounting rolldown projection screens on walls and ceilings. Because the wall studs or ceiling joists very rarely line up to match the attachment points on the screen casing, the installer is forced to fabricate an “adapter” to fasten the screen to the surface. In our diagram on the right, one can see a hypothetical screen outline and the wall studs behind it. As you can see the wall studs do not lie where the screen ends will be mounted so the installer has to make an adapter. This is generally done with a 1”x 6” wooden board that is fastened to the wall studs or ceiling joists and then the screen housing is fastened to it. The problem with this method is that it takes additional time and the wooden board must be painted to match the wall or ceiling - a awful lot of additional trouble.

Both Da-Lite, Vutec and Draper have come to the installer’s rescue with a system of movable mounting brackets that side along the length of the casing. These brackets allow the installer to “catch a stud” and then slide the screen horizontally to it’s preferred location. The brackets have come to be called “Floating Mounting Brackets” because the screen casing in essence is allowed to float sideways. We strongly recommend that you get floating mounting brackets if you purchase a rolldown screen. They make the job much easier. They are standard on all Vutec screens, on Draper’s Silhouette series and are an optional accessory on Da-Lite screens

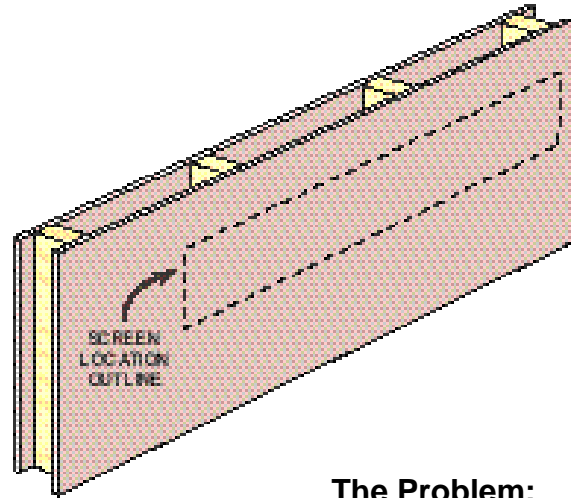

**The Problem:**  
Wall studs do not line up with screen casing location

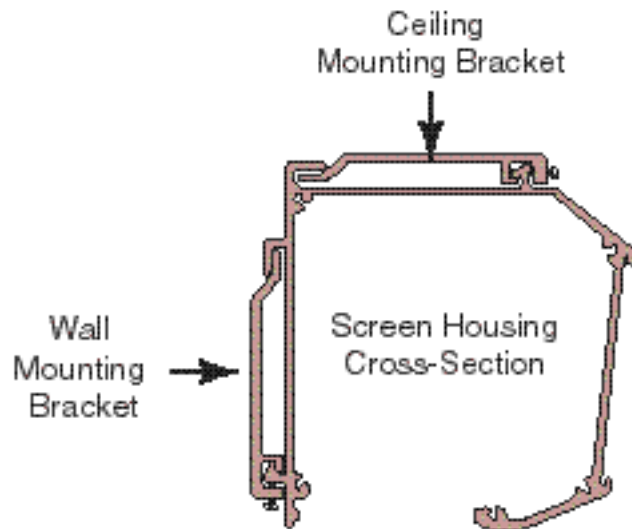

**The Solution:**  
Floating Mounting Brackets allow one to slide the casing sideways to position the screen in the best location



If you use a floating mounting bracket system, attaching a screen housing to walls or ceilings is a snap. All that is necessary is to securely attach the wall/ceiling mounting clips to a structural member "somewhat near" the left and right ends of the housings. Because there is a continuous channel for the mounting clips to attach to, the screen can be slid into the exact placement location without regard to the exact location of the mounting clips. For tutorial purposes, let's examine a typical screen installation.

In Diagram 1, below, we show a typical ceiling construction in a wood framed house. Note that the secure structural members are the 2x12 floor/ceiling joists. When hanging a screen, these are members that you want to attach to. Diagrams 3 and 4 on the next page illustrate this. In Diagram 2, we show a typical wall construction. In a wood framed house, the studs are most likely to be 2x4s, in commercial buildings they may be metal studs. Either way, the studs, wooden or metal, are the structural members that you want to attach the screen mounting clips to.

On the next page we illustrate several methods to hang a screen housing. Diagram 3 is the most basic, mounting to a standard blue board ceiling. Diagram 4 shows one method to hang a screen from a suspended ceiling and in the event you are dealing with a concrete structure, Diagram 5 illustrates one method to attach the screen directly to the concrete.

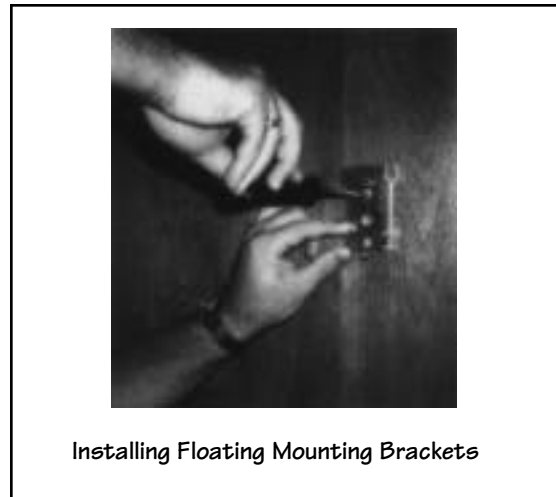

Installing Floating Mounting Brackets

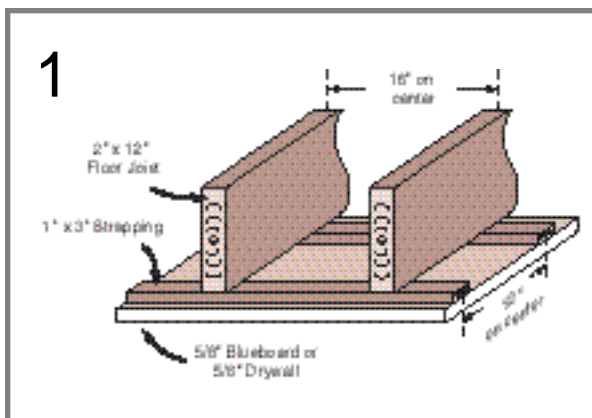
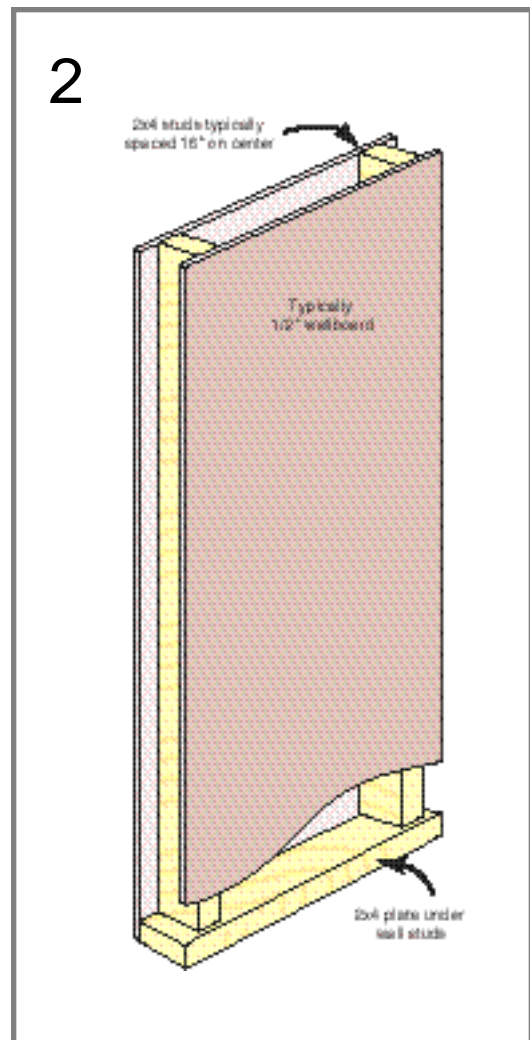



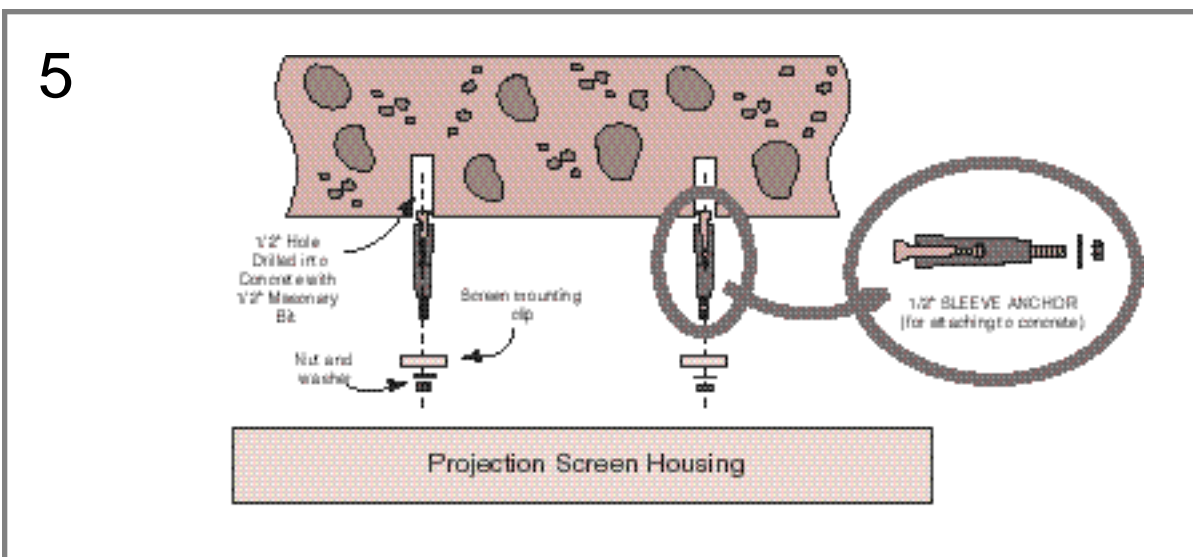
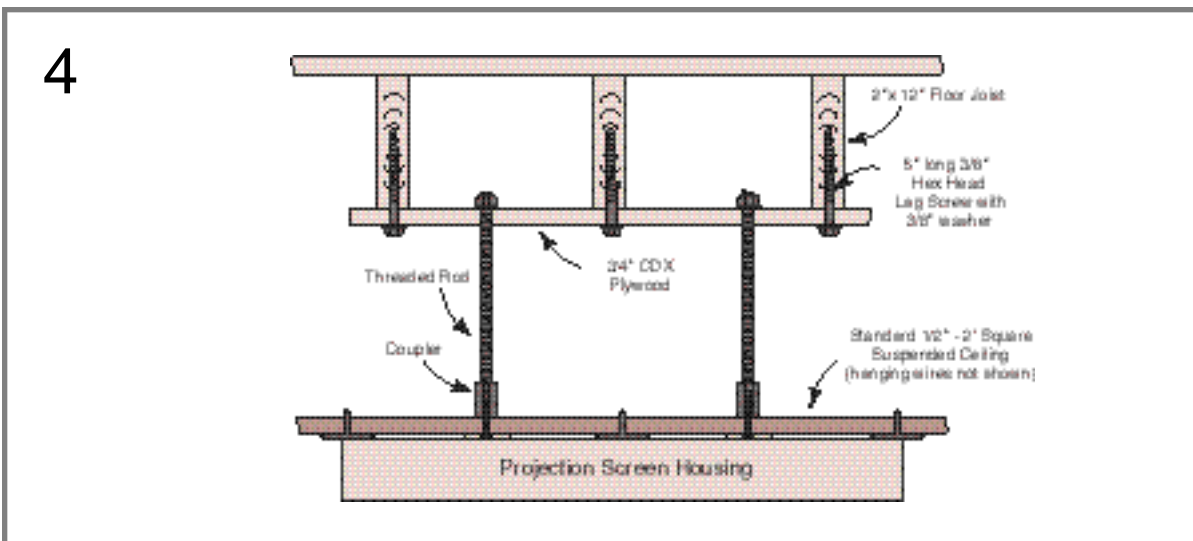
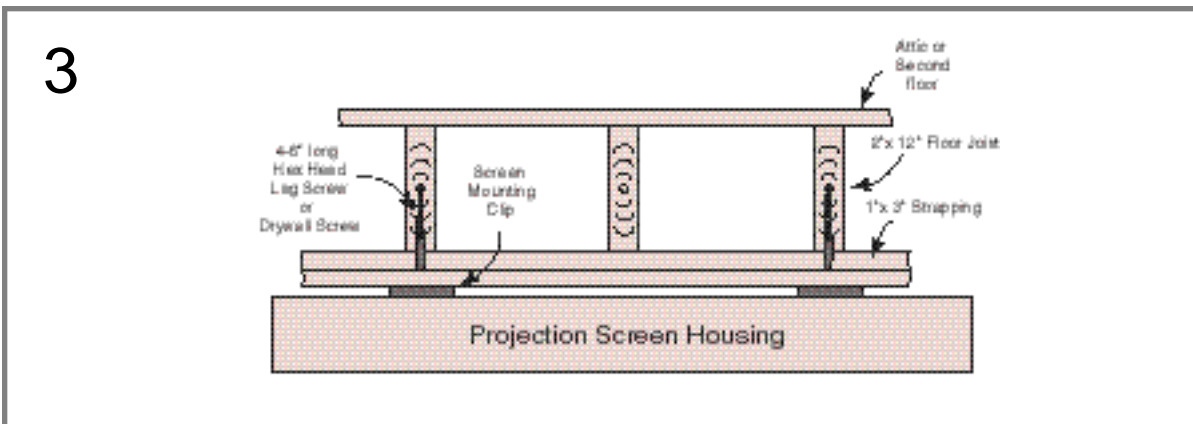



The process by which AC power cables are routed to a motorized screen varies depending on the building structure itself and whether you are installing the system in new construction or old construction. Here are a few tips on doing it in either type of building.

**New construction.** The obvious advantage of installing the screen wiring during the construction phase of a house is that you can "prewire" the power wires into the walls and/or ceiling. This saves an enormous amount of time compared with snaking them through the structure after the fact. The general prewiring method starts with visiting the site after the framing is completed and determining exactly where you want the screen and AC power wires to be located. After this, the power wires can be fed over to the screen location by drilling 1/2" holes in the center of the framing members (see photos below). When finished, many installers draw a diagram of the room and indicate the distance from the wires to the nearest reference wall. This makes finding your buried wires (and studs) much easier when you come back later to install the screen and the rest of the hardware.

**Old construction.** The process of installing wiring in an existing building usually involves the seemingly impossible task of snaking things from point A to point B through the structure of an existing building. If you are attempting a snaking job for the first time, remember learning to snake is an experiential process. The first few times are typically difficult, but after that most everyone has the hang of it. The main ingredient necessary is just a good dose of patience.

If the structure you are working on is less than 50 years old, the walls most likely consist of gypsum-based wall board. This substance is easy to cut with a drill and a keyhole saw and snaking is relatively easy. If the house is older than 50 years, you may find plaster and lath wall construction. Cutting a hole in plaster and lath walls can be tricky because it is often old and dry, and can crumble easily when you cut through it. Snaking is also difficult because the wall chambers are filled with ribs of plaster, and the snake may jam against them as you maneuver around. The secret is to take your time and be careful!



Leave the pre-wired AC power wires hanging in to stud bay and you can get to them after drywalling

Now, let's take a look at a typical screen power cable routing exercise step-by-step. In this example we are mounting a motorized screen flush on a standard stud wall and routing the power cables up through the wall from the basement. Some of the tools you may need are: a 3/8" or larger electric drill, installer's drill bits (long, 1/2" to 5/8" drill bits), and a standard wire snake.



AC Power wires routed through 3/4" holes drilled in the center of each framing member

**Step One:** Decide where you want to mount the screen on the wall. This often requires a copy of the projector-screen installation dimensions that typically come with the projection display device. If you haven't purchased the projector yet and you are pre-wiring, call the manufacturer for the dimensions. They should be able to fax you a copy of their installation charts.

After the location of the screen is determined, you can decide on the best spot for the screen power cables to come up through the wall. The electrical connections on the Vutec motorized screens are located in the left side of the screen housings so a natural place is right underneath the internally mounted electrical box (see our diagram). Mark a spot in that location for a hole to be drilled.

**Step Two:** Before you drill a good size hole in the marked location, it is best to find out what is behind the wall in that spot. You may find that you are right on a wall stud, wiring or plumbing, and will have to move the hole over slightly to avoid them. (Note: The standard method employed by custom installation professionals to find wall studs is to tap horizontally across the wall surface and listen for the dull reverberation of studs. You can also use an electronic stud finder but they typically do not work well in older plaster and lath wall construction). Start by drilling a small exploration hole in the wall and stop drilling as soon as you perforate the wall surface!

**Step Three:** With a small wire snake find out if you have any obstructions behind the hole. Assuming you do have a clear shot into the stud bay, drill a 1" hole for the romex wires to snake out of.

**Step Four:** Pinpoint the location of the stud bay overhead on the basement ceiling. (A stud bay is a carpenter's term for the area between any two 2x4 wall studs). This is easily done if you take several measurements in the room above and apply them to the basement ceiling. Be extra careful with these measurements or you could find yourself drilling into unintended areas, such as hardwood floors, etc. After you have good idea where the stud bay is, then carefully drill a hole up from underneath.

**Step Five:** Then work to get the wire snake up to the hole behind the screen. This is done by inserting the end of a wire snake into the hole you just drilled and twisting and probing your way up the wall section until it appears in the hole. At this point, having an assistant upstairs looking for the snake may be helpful.

**Step Six:** Once you have successfully pushed the snake wire from the basement to the hole, use the snake to pull the wires up through.

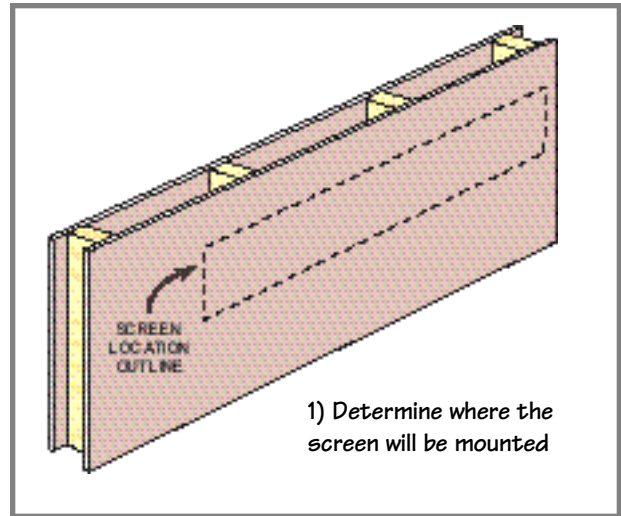

1) Determine where the screen will be mounted

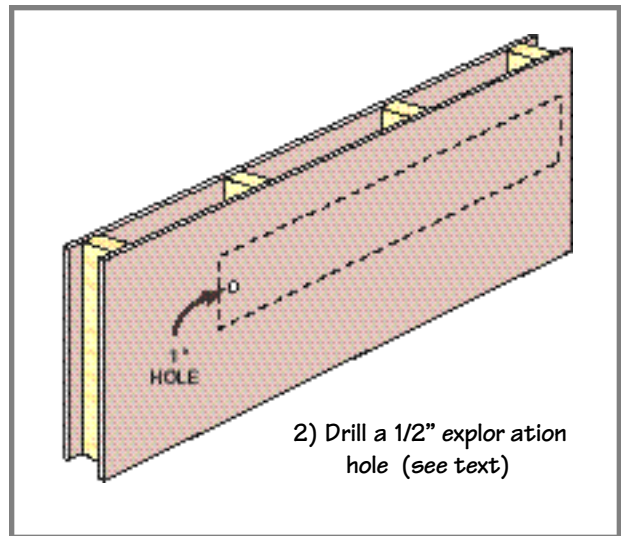

2) Drill a 1/2" exploration hole (see text)

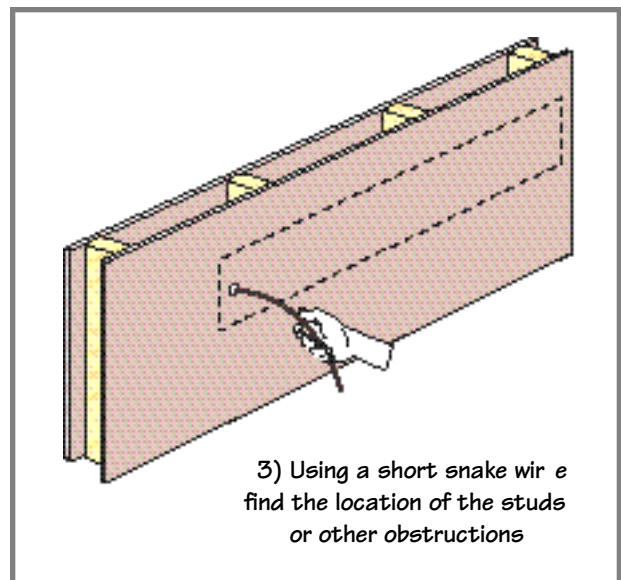

3) Using a short snake wire find the location of the studs or other obstructions



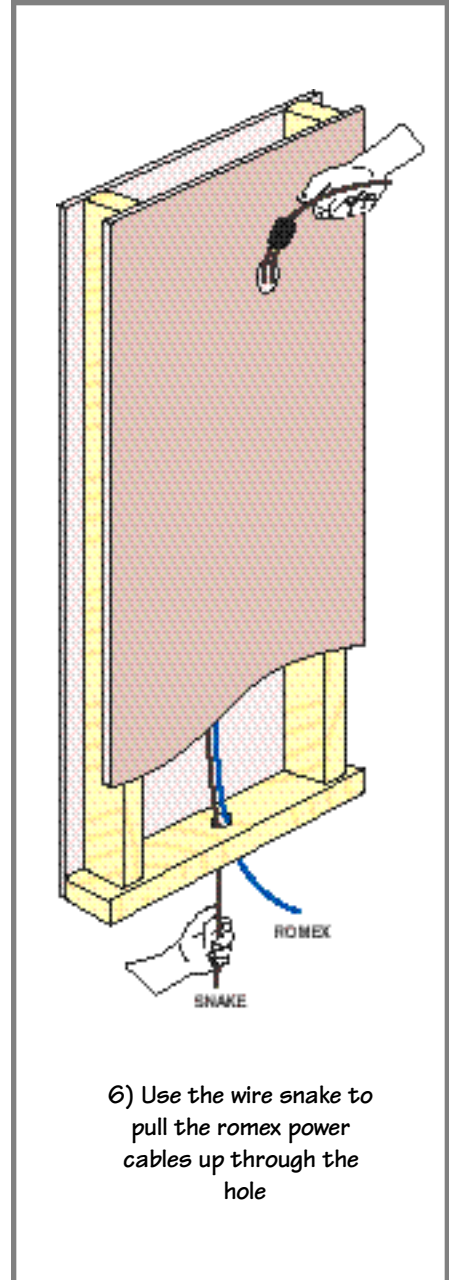
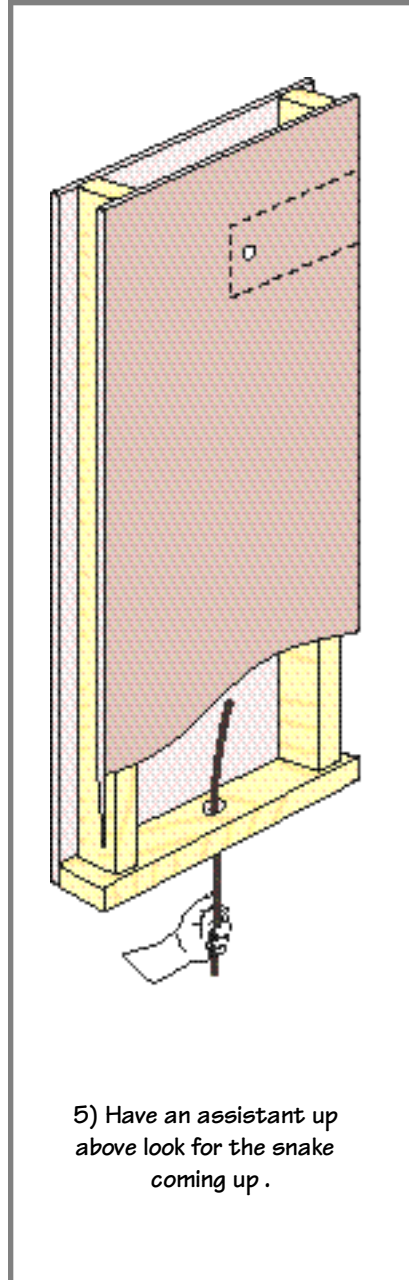
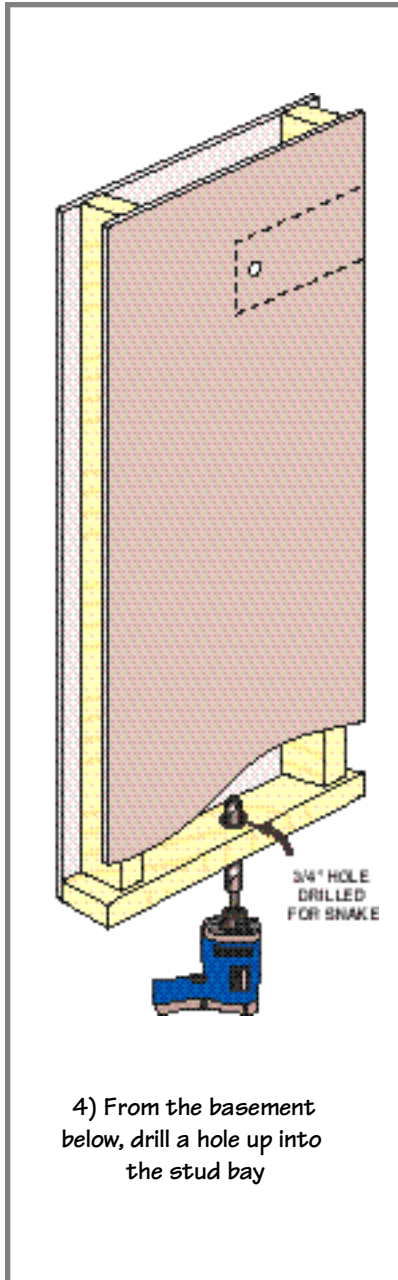

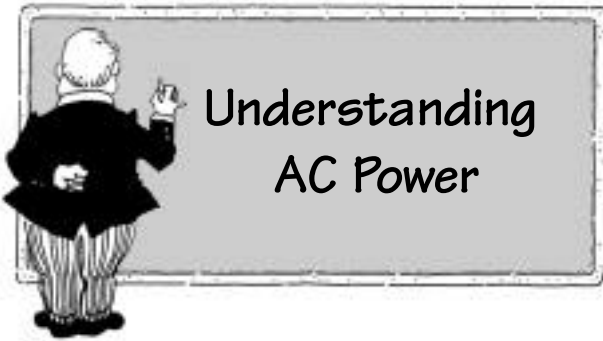

## Understanding AC Power

Honestly, it is beyond the scope of this handbook to provide an overview of AC power and the National Electrical Code, in most installations these details are best taken care of by a licensed electrician. However, when installing a motorized screen, it is good to understand the concepts, so here's a few to consider. First, in retrofit situations where the building is already completed, it is often necessary to tap into an existing circuit for screen power. Note that this should be done only if the circuit can provide enough amps to power the screen and any other items connected, typically, a 20 amp circuit is desired. Below we illustrate how the wiring circuits in a typical building are derived from the power coming in. In the average residential house, circuits will be a mix of 15 and 20 amp circuits. In new construction, it is best to put a motorized screen on it's own 15 to 20 Amp circuit. The reason for this is not that screens draw so much continuous power (as matter of fact, most of the time they are drawing no power at all), it's that during startup, any motorized device has a high "in-rush" current draw. In the diagram right, we show the power drawn by a small AC motor during the first few milliseconds of use. This in-rush power draw is better sourced from a dedicated circuit than from one that is loaded with lots of other devices turning on at the same time.

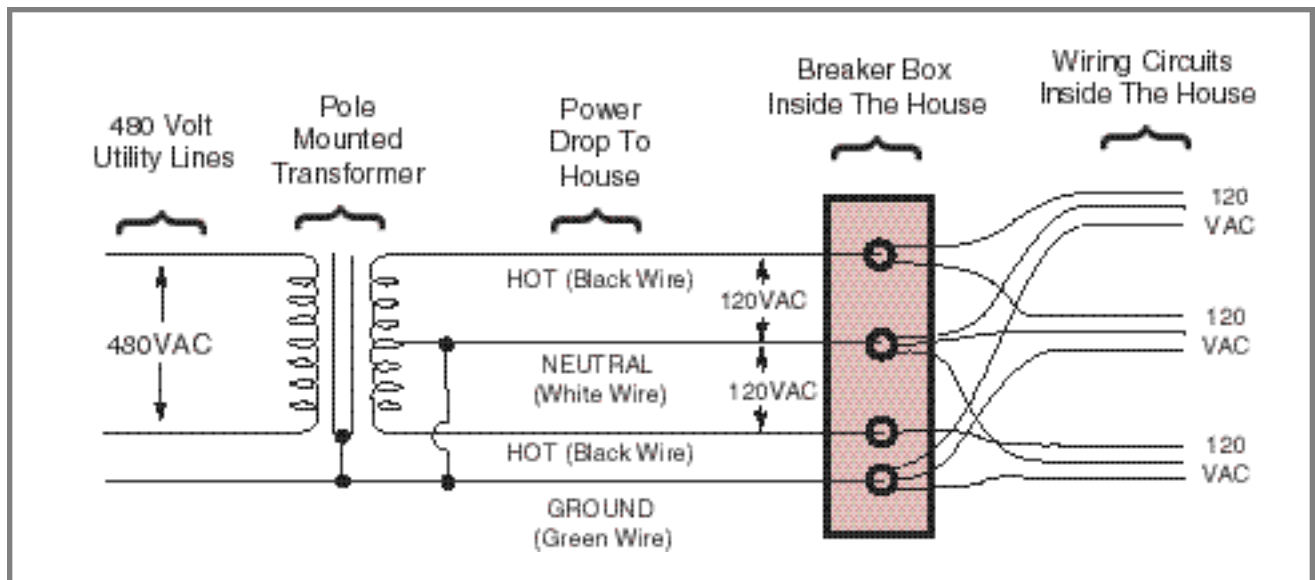
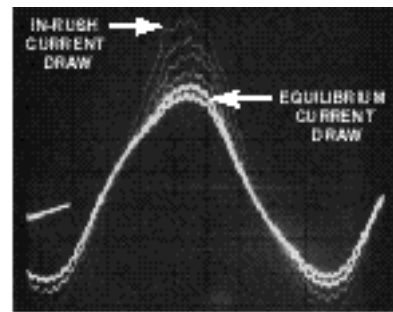
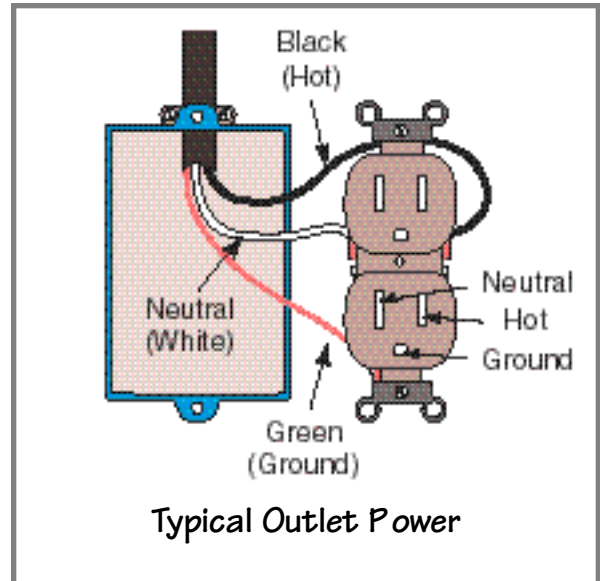

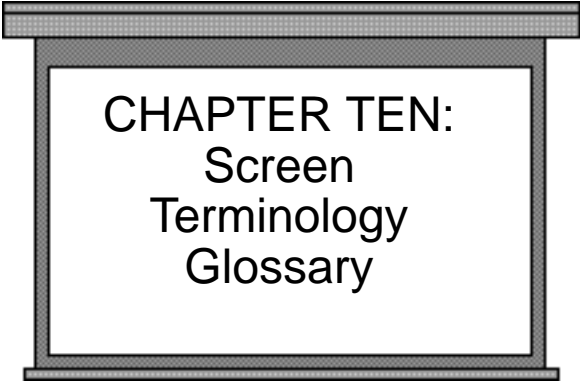

## CHAPTER TEN: Screen Terminology Glossary

**Ambient Light:** The light in a viewing room produced by sources other than the screen

**Aspect Ratio:** The numeric relationship between a screen's height and width. Generally speaking an aspect ratio defines a "shape".

**Black Drop:** On a rolldown flat screen this is the area that is black on the top or bottom of the picture areas.

**Brightness:** A viewer's subjective response to a display's luminance

**Contrast ratio:** The numeric relationship between the brightest and darkest portions of a video display. It is generally expressed in foot-lamberts as a ratio of max/min.

**CRT:** Cathode ray tube, a vacuum tube where electrons are drawn to phosphor targets via high voltage potentials. This is the technology behind standard "picture" tube-type televisions.

**DLP:** Digital light processor, a technology based on the Texas Instruments DMD micromirror imaging chips. These chips have a field of reflecting mirrors that can be modulated to produce video images.

**Foot-Lambert:** A unit of luminance equivalent to 1 lumen per square foot.

**Fresnel Lens:** A device constructed of a large number of closely spaced concentric circles cut into an optical surface. The circles are cut so that they reduce the incident bend angles of the projection source and collimate the light into one beam.

**Gain:** A measurement of the amount of light radiating perpendicularly from a screen. Unity gain (a gain of 1) is generally standardized via a block of magnesium carbonate.

**LCD:** Liquid Crystal Display, a technology of video display that uses liquid crystal "shutters" to modulated the light passing through the imaging chips. Also referred to as "Transmissive LCD technology".

**Lens Speed:** The ability of a lens to pass light. Expressed in a ratio, it is the focal length of the lens divided by the effective diameter of the lens. A fast lens passes more light and gets a lower rating.

**Lumen:** The quantity of visible light falling on a 1 square foot surface of a sphere 1 foot in radius as radiated by a source of 1 standard candle. This specification is often used to rate the light output of video projectors. Look for ANSI lumen ratings, it is a standardized measurement.

**Luminance:** The brightness of a light source measured in foot-lamberts.

**Pixel:** A picture element. On digital devices, images are usually constructed of pixels fields divided into rows and columns.

**Resolution:** The limit of a display's ability to present fine detail. "Optical resolution" is usually the number of lines seen, "video resolution" is usually the number of "line pairs" seen.

**Scan Lines:** A CRT-based video display creates images by rapidly sweeping electron beam across a phosphor target. As these lines are swept from top to bottom they create scan lines.

**Throw Distance:** The distance from the screen surface to a video display device. This is an important number used in the installation of a video display.

**Viewing Angle:** An angle that specifies a particular viewing location measured from a perpendicular from the screen surface.





NOTES: